

# VIBRATION MONITOR CX-RLY



---

MaintTech  
Norrkoping Airport  
Sweden  
Email: [mainttech@live.se](mailto:mainttech@live.se)  
Website: [www.mainttech.se](http://www.mainttech.se)



# CX-RLY-C MODULE

Version 1

## 1 Important User Information

Solid-state equipment has operational characteristics differing from those of electromechanical equipment. Safety Guidelines for the Application, Installation, and Maintenance of Solid State Controls describes some important differences between solid-state equipment and hard-wired electromechanical devices. Because of this difference, and because of the wide variety of uses for solid-state equipment, all persons responsible for applying this equipment must satisfy themselves that each intended application of this equipment is acceptable.

Throughout this manual, when necessary, we use notes to make you aware of safety considerations.



**ATTENTION:** Identifies information about practices or circumstances that can lead to personal injury or death, property damage, or economic loss. Attentions help you identify a hazard, avoid a hazard, and recognize the consequence

### IMPORTANT

Identifies information that is critical for a successful application and understanding of the product.

The CX-RLY-C module is built using a Micro810™ 12 Point Programmable Controller.

A more detailed description of how to install and use the Micro810 programmable controller may be found on the following link:

<http://ab.rockwellautomation.com/Programmable-Controllers/Micro810>

## 2 Overview

The CX-RLY-C Modules are smart relays with high current relay output models and can be configured through the embedded LCD display without any programming software.

### 2.1 Installation Considerations

Locate your modules as far as possible from power lines, load lines, and other sources of electrical noise such as hard-contact switches, relays, and AC motor drives.

**WARNING:** Exposure to some chemicals may degrade the sealing properties of the materials used in the Relays. It is recommended to the User to inspect these devices periodically to observe any degradation of properties and to replace the module if degradation is found.

**WARNING:** To comply with the CE Low Voltage Directive (LVD), this equipment must be powered from a source compliant with the following: Safety Extra Low Voltage (SELV) or Protected Extra Low Voltage (PELV).

**WARNING:** Do not wire more than two conductors on any single terminal.

**WARNING:** Be careful when stripping wires. Wire fragments that fall into the module could cause damage. Once wiring is complete, make sure the controller is free of all metal fragments.

**ATTENTION:** This product is intended to be mounted to a well-grounded mounting surface such as a metal panel. Additional grounding connections from the power supply mounting tabs or DIN rail (if used) are not required unless the mounting surface cannot be grounded.

**ATTENTION:** Circuits installed on the machine for safety reasons and interlocks, should always be hard-wired directly to the master control relay. These devices must be wired in series so that when any one device opens, the master control relay is de-energized, thereby removing power to the machine. Never alter these circuits to defeat their function. Serious injury or machine damage could result.

## 2.2 Preventing Excessive Heat

For most of the applications, normal convective cooling keeps the CX-RLY-C module within the specified operating range. Ensure that the specified temperature range is maintained. A proper spacing of the components within an enclosure is usually sufficient for heat dissipation. In some applications, a substantial amount of heat is produced by other equipments inside or outside the enclosure. In this case, place blower fans inside the enclosure to assist in air circulation and to reduce “hot spots” near the module.

Additional cooling provisions might be necessary when high ambient temperatures are encountered.

### **TIP**

*Do not bring in unfiltered outside air. Place the module in an enclosure to protect it from a corrosive atmosphere. Harmful contaminants or dirt could cause improper operation or damage to components. In extreme cases, you may need to use air conditioning to protect against heat buildup within the enclosure.*

## 2.3 Mounting Dimensions

Mounting dimensions do not include mounting feet or DIN rail latches.

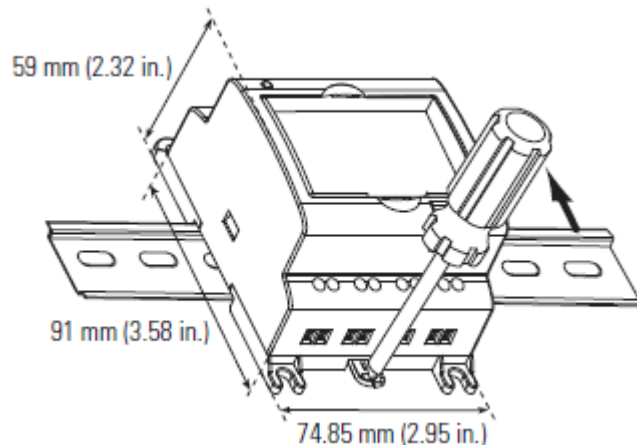

The module can be mounted using the following DIN rails: 35 x 7.5 mm x 1 mm (EN 50 022 - 35 x 7.5).

Before mounting the module on a DIN rail, use a flat-blade screwdriver in the DIN rail latch and pry it downwards until it is in the unlatched position.

- a) Hook the top of the DIN rail mounting area of the module onto the DIN rail, and then press the bottom until the module snaps onto the DIN rail.
- b) Push the DIN rail latch back into the latched position.  
Use DIN rail end anchors for vibration or shock environments.  
To remove your module from the DIN rail, pry the DIN rail latch downwards until it is in the unlatched position.

## 2.4 Wiring Diagram



**WARNING:** Before installing and wiring any device, just disconnect power supply of the module.

The following picture shows the wiring diagram of the module:

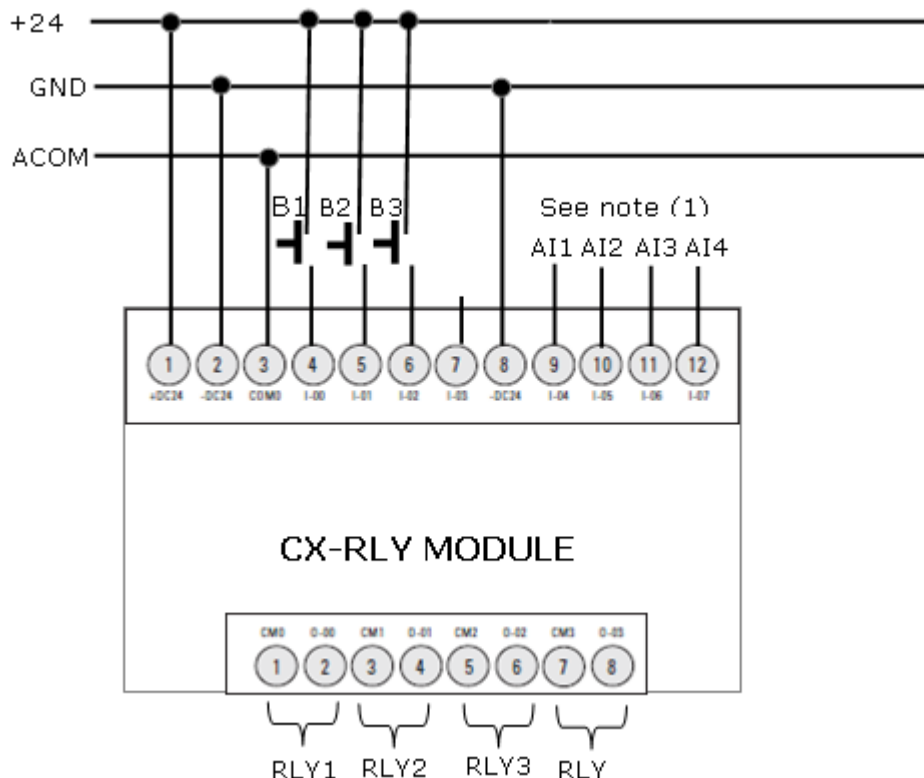

**AI1<sup>1</sup>** – Analogical Input 1 (0..6 V dc)

**AI2<sup>1</sup>** – Analogical Input 2 (0..6 V dc)

**AI3<sup>1</sup>** – Analogical Input 2 (0..6 V dc)

**AI4<sup>1</sup>** – Analogical Input 2 (0..6 V dc)

**ACOM** – Common for Analogical Input

**B1** – LOCK. When closes, locks the keypad.

**B2** – STARTUP. When a transition from “0” to “1” occurs, the alarm limits will be multiplied with a factor of 2, for 10 seconds.

**B3** – INHIBIT – When closes, inhibits the relays action. Relays will be placed in no-alarm status (NC or NO, depending on B4 input).

**RLY1** – RELAY 1 free contact (can be set to NC or to NO).

**RLY2** – RELAY 2 free contact (can be set to NC or to NO).

**RLY3** – RELAY 3 free contact (can be set to NC or to NO).

**RLY4** – RELAY 4 free contact (can be set to NC or to NO).

<sup>1</sup> AI2, AI3 and AI4 analogical inputs can be used to disable Channel 4, 3 and 2. See "4.1. Channel configuration" paragraph.

## 2.5 Analog Channel Wiring Guidelines

Consider the following when wiring your analog channels:

- The analog common (COM) is connected to power supply common inside the module. These terminals are not electrically isolated from the system.
- Analog channels are not isolated one from each other.
- Use Belden 8761, or equivalent, shielded wire.
- Under normal conditions, the drain wire (shield) should be connected to the metal mounting panel at field side (earth ground). Keep the shield connection to earth ground as short as possible.
- To ensure an optimum accuracy for voltage inputs, just limit the overall cable impedance by keeping all analog cables as short as possible. Locate the CX-RLY-C module as close to your vibration converter as possible.

**NOTE:** Inputs on analog channels employ digital high-frequency filters that significantly reduce the effects of electrical noise on input signals. However, because of the variety of applications and environments where analog controllers are installed and operated, it is impossible to ensure that the input filters will remove all environmental noise.

## 2.6 Status Indicator of the module

State	During Operation
Off	No power applied to device, or in Fault mode
Solid green	Device operating normally
Flashing green	Operating System error

### 3 CX-RLY-C SPECIFICATION

Parameter	CX-RLY-C
Number of I/O	8 Input (4 digital, 4 analog/digital) 4 Output
Dimensions HxWxD	91 x 75 x 59 mm
Supply voltage range	20.4...26.4V DC
Power consumption	3 W
I/O rating	Input: 24V DC, 8 mA Relay : 4 A @ 240V AC
Shipping weight, approx.	0.203 kg
Wire size	0.32... 2.1 mm <sup>2</sup> (22...14 AWG) solid copper wire or 0.32... 1.3 mm <sup>2</sup> (22...16 AWG) stranded copper wire rated @ 90 °C insulation max.
Enclosure type rating	Meets IP20
<b>DC Inputs</b>	
On-state voltage, nom	12/24V DC
On-state voltage, min	9.8V DC
On-state voltage, max	28.8V DC
Off-state current, max	0.5 mA
On-state current, min	0.75 mA @ 10.8V DC 1.0 mA @ 15V DC
On-state current, nom	2.1 mA @ 24V DC
On-state current, max	2.7 mA @ 28.8V DC
Nominal impedance	14.1 KOhm
<b>Analog Inputs</b>	
Input type	DC voltage
Input voltage range	0...6V DC accepted
Input voltage, max	26.4V DC
Value of LSB	10 mV
Overall accuracy	2% of full-scale (with calibration) (25...55 °C)
Noise rejection	50/60 Hz
Common mode rejection	40 dB, DC to 60 Hz with smoothing filter
Nominal impedance	14.1 kΩ (non-isolated)
<b>Relay Outputs</b>	
Output rating	4 A @ 240V AC, 2 A @ 24V DC,
Voltage, min	5V AC/DC
Voltage, max	250V AC, 30V DC @ rated current.
Mechanical	10,000,000 cycles
Electrical with rated load	50,000 cycles
<b>Environmental</b>	
Temperature, operating	IEC 60068-2-1 (Test Ad, Operating Cold), IEC 60068-2-2 (Test Bd, Operating Dry Heat), IEC 60068-2-14 (Test Nb, Operating Thermal Shock): 0...55 °C
Surrounding air temperature, max.	55 °C
Temperature, storage	-40...85 °C

Relative humidity	IEC 60068-2-30 (Test Db, Unpackaged Damp Heat): 5...95% non-condensing
Vibration	IEC 60068-2-6 (Test Fc, Operating): 2 g @ 10...500 Hz
Shock, operating	IEC 60068-2-27 (Test Ea, Unpackaged Shock): 30 g
Shock, non-operating	IEC 60068-2-27 (Test Ea, Unpackaged Shock): 30 g (DIN Rail Mounted)
ESD immunity	IEC 61000-4-2: 4 kV contact discharges 8 kV air discharges
<b>Certifications</b>	
CE	European Union 2004/108/EC EMC Directive, compliant with: EN 61000-6-2; Industrial Immunity EN 61000-6-4; Industrial Emissions

### Access the module Configuration Menu

Press **ESC** and **OK** at the same time, to access the **Main Menu** screen.



Accessing this menu when the machine is running can lead to personal injury or death, property damage, or economic loss. Before accessing this menu, be sure that the machine is not running. For safety reasons, the Configuration menu is password protected.

---

## 4 Functional description

### 4.1 Channel configuration



**WARNING:** Before you configure and wire any device, disconnect power to the module.

---

The CX-RLY-C module can be configured to accept 1, 2, 3 or 4 analogical inputs.

Inputs 2, 3 and 4 can be disabled.

In the channel configuration, there are a few restrictions:

- Channel 2 can be disabled only if channels 3 and 4 are also disabled.
- Channel 3 can be disabled only if channel 4 is also disabled.
- Channel 4 can be disabled without any restriction.

To disable a channel, just connect the selected input to +24 V.

In the following tables are presented the options:

**Table 1 - Channel 4 disabled**

Input	Connection
AI1	To analogical source (0..5V dc or 1..5V)
AI2	To analogical source (0..5V dc or 1..5V)
AI3	To analogical source (0..5V dc or 1..5V)
AI4	Connect to +24V

**Table 2 - Channel 3 and 4 disabled**

Input	Connection
AI1	To analogical source (0..5V dc or 1..5V)
AI2	To analogical source (0..5V dc or 1..5V)
AI3	Connect to +24V
AI4	Connect to +24V

**Table 3 - Channel 2, 3 and 4 disabled**

Input	Connection
AI1	To analogical source (0..5V dc or 1..5V)
AI2	Connect to +24V
AI3	Connect to +24V
AI4	Connect to +24V





**Table 4 - All channels enabled**

Input	Connection
AI1	To analogical source (0..5V dc or 1..5V)
AI2	To analogical source (0..5V dc or 1..5V)
AI3	To analogical source (0..5V dc or 1..5V)
AI4	To analogical source (0..5V dc or 1..5V)



## 4.2 KEYPAD

The module keypad has 6 keys.

	<p><b>UP/DOWN</b> arrow keys In the <b>Main</b> Screen: these keys select an analogical channel. In the <b>Setting</b> screens: with these keys the set value can be changed.</p>
	<p><b>OK</b> Key In the <b>Main</b> Screen: when pressing this key, the software will move to the first <b>Setting</b> screen (for the selected channel). In the <b>Setting</b> screens: Save the setting after it was changed.</p>
	<p><b>LEFT/RIGHT</b> arrow keys In the Main Screen, these keys are not used. In the Setting screens, these keys browse between the Setting screens (for the selected channel).</p>
	<p><b>ESC</b> key In the <b>Main</b> screen: By pressing this key, the software will access the GENERAL <b>Setting</b> screen. In the <b>Setting</b> screens, the key may be used to return directly to the <b>Main</b> Screen.</p>



## 4.3 Main Screen

**Main** screen is always the first one that appears.



The vibration values coming from the analogical inputs are shown in four lines.



Press  to select a channel. This action is required, if you need to change the channel setting. After selection, just press  to access the Setting menu.

Press (3 seconds)  to access the GENERAL setting screen.

Depending on the general hardware settings and depending on the alarm condition, the Main screen can look like below (Refer to paragraph 2.4 "Wiring Diagram").

### 4.3.1 The keypad is locked

CH1	7.8 mm/s
CH2	3.2 mm/s
CH3	4.1 mm/s
CH4	1.3 mm/s

**I-00** Digital input is connected to +24 V (**LOCK=True**)

Selection arrow sign ▶ is not visible.

This hardware setting disables the access to the Setting screens.

### 4.3.2 The relay is inhibited

▶ CH1	7.8	INH
CH2	3.2	INH
CH3	4.1	INH
CH4	1.3	INH

**I-02** Digital input is connected to +24 V (**INHIBIT** =True)

When the relay is inhibited, the alarm condition is not evaluated and the relays will be placed in non-alarm condition (NC or NO, depending on **I-03** hardware status).

Normally, it is necessary to place the CX-RLY-C module in this status, only for troubleshooting.

### 4.3.3 A channel is in alarm condition

▶ CH1	7.8	
CH2	3.2	WAR
CH3	4.1	DNG
CH4	1.3	

In the picture, CH2 is in alarm status (the measured value is above the set **Warning**).

CH3 is also in **Danger** status.

The correspondent relay will act only when the **delay** time will expire.

## 4.4 GENERAL setting screens



Accessing this menu when the machine is running can lead to personal injury or death, property damage, or economic loss. Before accessing this menu, be sure that the machine is not running.

CX-RLY-C accepts two voltage ranges: 0-5 V dc or 1-5 V d.c.

To access this screen, from the **Main** screen just press ESC for 3 seconds.

### 4.4.1 INPUT CONFIG SCREEN

INPUT CONFIG	
0 - 5 V	[◆]
Save?	[OK]
[◀]Main	Next [▶]

Use ▲/▼ arrows to change the voltage input range.

Press **OK** to save the settings.

Press **ESC** to exit to the **Main** screen.

**NOTE:** 1 - 5 V setting is suitable for Loop Vibration Sensor having a 4...20 mA output.

Press ◀ to return to the **Main** screen.

Press ▶ to go to the RLY #1 NORMAL position screen.

### 4.4.2 RELAY NORMAL POSITION

RLY1 NORMAL	
CLOSE	[◆]
Save?	[OK]
[◀]Prev	Next [▶]

Use ▲/▼ arrows to change the Relay #1 normal position (CLOSE or OPEN).

Press **OK** to save the settings.

Press **ESC** to exit to the **Main** screen.

Press ◀ to return to the INPUT CONFIG screen.

Press ▶ to go to the RLY #2 NORMAL position screen.

The next three screens are similar, for setting RLY #2, RLY #3 and RLY #4.

**NOTE:** Relay normal position defines the contact status in **NORMAL** operation (**NO** alarm), as follows:  
 - **CLOSE** - In **NO** alarm condition the relay coil is energized and the relay contact is closed.  
 - **OPEN** - In **NO** alarm condition the relay coil is de-energized and the relay contact is opened.

#### 4.5 SETTING Screens

For each channel, there are 6 Settings screens:

- RANGE screen
- WARNING screen
- DANGER screen
- DELAY screen
- WARNING RLY mapping
- DANGER RLY mapping

To entry in the **SETTING** screens, from the **Main** screen, first select the channel and then press **OK**.

The settings for CH1 are shown below. For the other channels, the settings will be done in a similar manner.

##### 4.5.1 RANGE SETTING SCREEN

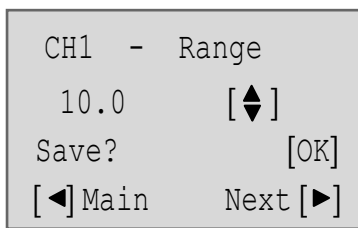

Use ▲/▼ arrows to change the range value, in a step of 10. The selection can be done for ranges between 10 and 100.  
 Press **OK** to save the new settings. The third line is visible only when the new value is not the same with the previous saved value.  
 Press ◀ to return to the **Main** screen.  
 Press ▶ to go to the **Warning** screen.  
 Press **ESC** to return to the **Main** screen directly.



**WARNING:** The range must be set according with the range of the the vibration converter. A wrong setting can let the machine without protection.

##### 4.5.2 WARNING SETTING SCREEN

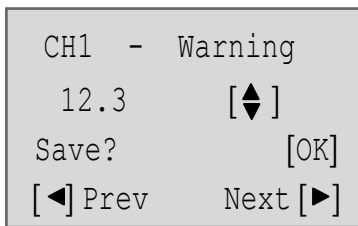

Use the ▲/▼ arrows to change the **Warning** value, in a step of 0.1. The selection can be done for the alarm between 0.1 and the **Range** value, already set in the screen above.  
 To accelerate the modifying procedure, just press the ▲/▼ arrows for a couple of seconds.

Press **OK** to save the new setting. The third line is visible only when the new value is not the same with the previous saved value.

Press ◀ to return to the **Range** screen.

Press ▶ to go to the **Danger** screen.

Press **ESC** to return directly to the **Main** screen.

### 4.5.3 DANGER SETTING SCREEN

```
CH1 - Danger
12.3 [◆]
Save? [OK]
[◀] Prev Next [▶]
```

Use ▲/▼ arrows to change the **Danger** value, in a step of 1. The selection can be done for ranges between 0 and 10.  
Press **OK** to save the new setting. The third line is visible only when the new value is different from the previous saved value.  
Press ◀ to return to **Warning** screen.  
Press ▶ to go to the **Danger** screen.

Press **ESC** to return directly to the **Main** screen.

### 4.5.4 DELAY SETTING SCREEN

```
CH1 - Delay
3.0 sec [◆]
Save? [OK]
[◀] Prev Next [▶]
```

Use ▲/▼ arrows to change the **Delay** value, in a step of 0.1 seconds.  
Press **OK** to save the new settings. The third line is visible only when the new value is not the same with the previous saved value.  
Press ◀ to return to **Danger** screen.  
Press ▶ to go to the next screen.

Press **ESC** to return to the MAIN screen directly.

The **Delay** setting is used to add a delay time for relay action.

If an alarm condition occurs and a **Delay** time is set (non-zero value), the relay will act only if the alarm condition persists more than the set delay time. Otherwise, the relay will not act.

With another words, if the alarm condition persists less than **Delay** setting, the relay will remain in non-alarm condition (NO or NC).



**WARNING:** A too long delay time is not recommended. To avoid early trip during machine start-up, just use instead the STARTUP digital input. (See paragraph 4.4)



**WARNING:** During the setting procedure, the software doesn't evaluate the alarm condition and the relay won't be activated. The machine remains without protection!  
For safety reasons, the parameter settings must be done when the machine is stopped.

### 4.5.5 WARNING RLY MAPPING SCREEN

```
CH1 - Map Warn
▶ None [◆]
Save? [OK]
[◀] Prev Next [▶]
```

Use ▲/▼ arrows to change the mapping:  
Selection: None, RLY1, RLY2, RLY3, RLY4.  
Press **OK** to save the new settings. The third line is visible only when the new value is not the same with the previous saved value.  
Press ◀ to return to previous screen.  
Press ▶ to go to the next screen.

Press **ESC** to return to the **Main** screen directly.

#### 4.5.6 DANGER RLY MAPPING SCREEN

```
CH1 - Map Dang
▶ RLY2      [◆]
Save?       [OK]
[◀] Prev    Main [▶]
```

Use ▲/▼ arrows to change the mapping:

Selection: None, RLY1, RLY2, RLY3, RLY4.

Press **OK** to save the new settings. The third line is visible only when the new value is not the same with the previous saved value.

Press **◀** to return to previous screen.

Press **▶** to go to the next screen.

Press **ESC** to return to the **Main** screen directly.

These settings must be logically done, otherwise unexpected relay actions may occur.

##### Example 1 - Wrong relay mapping

Assuming that the RLY1 mapping was done as follows:

- CH1 Map Warn -> RLY1

- CH1 Map Dang -> RLY1

In this case, when a *Warning* alarm condition is met, the RLY1 will act, but nothing happens when a *Danger* alarm of CH1 occurs (RLY1 is already activated).

##### Example 2 - Wrong relay mapping

- CH1 MAP WARN -> RLY1

- CH2 MAP DANG -> RLY1

Above setting not have any sense. RLY1 is acting for two independent events, having nothing in common.

##### Example 3 - Correct relay mapping

Consider a CX-RLY-C used for a single machine, having four transducers.

A possible relay mapping is:

- RLY1 - *Warning* alarm (for all four channels: CH1, CH2, CH3 and CH4)

- RLY2 - *Danger* alarm (for all four channels: CH1, CH2, CH3 and CH4)

- RLY 3 - Set to NONE (unused)

- RLY 4 - Set to NONE (unused).

##### Example 4 - Correct relay mapping

Considering a CX-RLY-C used for two machines:

- Machine #1 - CH1 and CH2

- Machine #2 - CH3 and CH4

A suitable relay mapping may be this:

- RLY1 - *Warning* alarm for Machine#1 (CH1 Map Warn -> RLY1 and CH2 Map Warn-> RLY1)

- RLY2 - *Danger* alarm for Machine#1 (CH1 Map Dang-> RLY2 and CH2 Map Dang -> RLY2)

- RLY3 - *Warning* alarm for Machine#2 (CH3 Map Warn -> RLY3 and CH4 Map Warn-> RLY3)

- RLY4 - *Danger* alarm for Machine#2 (CH4 Map Dang-> RLY3 and CH4 Map Dang -> RLY3)

##### Example 5. Correct relay mapping

Map the relay as follows:

- RLY1 - *Danger* alarm for CH1 (CH1 Map Dang -> RLY1)

- RLY2 - *Danger* alarm for CH2 (CH2 Map Dang -> RLY2)

- RLY3 - *Danger* alarm for CH3 (CH3 Map Dang -> RLY3)

- RLY4 - *Danger* alarm for CH4 (CH4 Map Dang -> RLY4)

#### 4.6 STARTUP hardware switch

During start-up, a higher vibration value is expected.

To inhibit the alarm is not a suitable action, because the machine will remain for a while without protection for over-vibration.

That's why, in CX-RLY-C software was implemented a function which can, by demand, to double the set alarm limits.

This function must be used in conjunction with the digital input **I-01 (STARTUP)**.

When a transition from "0" to "1" occurs, the alarm limits will always be multiplied by a factor of 2, for 10 seconds only. This time allows the machine to stabilize when starts. If still exaggerate vibration values are measured, the machine will be stopped. After 10 seconds, the **I-01 (STARTUP)** input is ignored, until the next low-to-high transition.

This input must be always activated by an external relay, when the machine starts.

Trough the external relay contact, feed to the **I-02** digital input a +24 V voltage.

#### 4.7 Alarm hysteresis

To avoid repeatedly switching of the relay contact, a hysteresis gap has been implemented. The hysteresis value is 3% of the set RANGE.

See below the relay switching diagram:

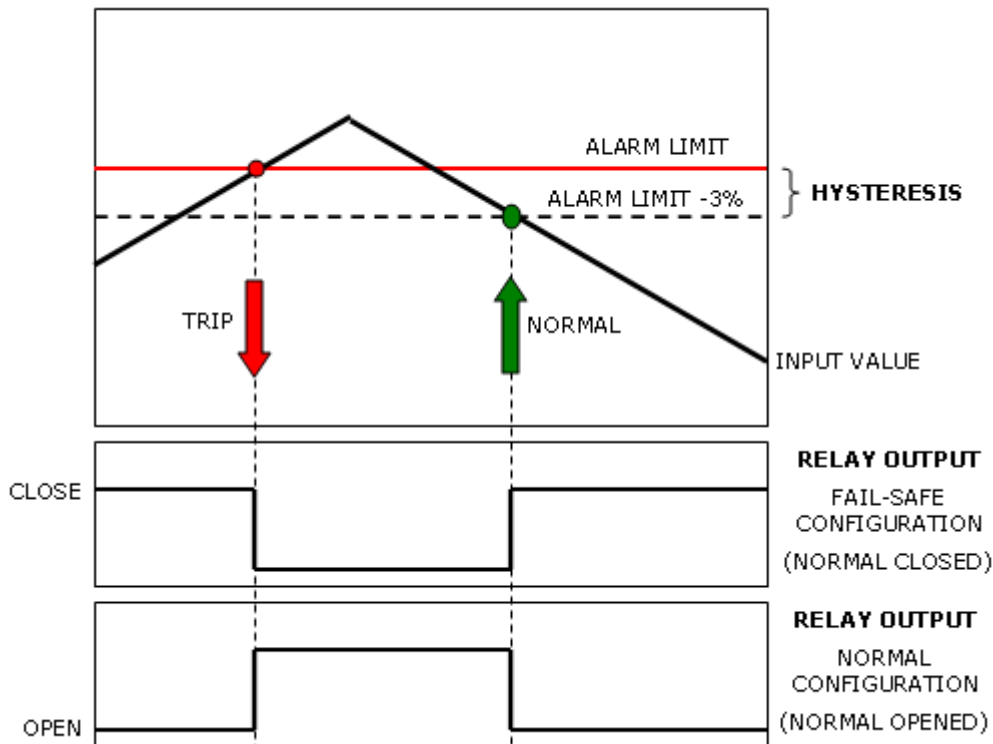

The hysteresis value is fixed and cannot be adjusted in this software release.